



13FMR-1 13CM (2.4 GHZ) Band FM ATV Receiver



FREQ MHz	1	2	3	4
2407	0	0	0	0
2398	1	0	0	0
2417	0	1	0	0
2410	1	1	0	0
2430	0	0	1	0
2413	1	0	1	0
2418	0	1	1	0
2420	1	1	1	0
2441.5	0	0	0	1
2425	1	0	0	1
2428	0	1	0	1
2432	1	1	0	1
2433	0	0	1	1
2434	1	0	1	1
2435	0	1	1	1
2442	1	1	1	1

This imported FM video receiver has been converted by us to receive in the 13cm ham bands. The frequencies are selected by the front panel digiswitch - on each switch position vs. frequency on the chart, up is 1 and down is 0. If other frequencies are desired in the ham bands, the PIC can be replaced with one special programmed by us however the AFC is very wide and will lock on to frequencies typically within 10 MHz of the channel frequency.

A wall plug power supply is provided, however, the receiver can be powered from any 12 to 14 Vdc power supply @ 250 ma.

The front panel has video and line audio RCA jack outputs. Sound subcarrier is 5.5 or 6.0 MHz as specified at time of purchase. 6.0 is standard. Video de-emphasis may or may not be used on this ham band but is not built into this unit and must be added if used in your area. Pre-emphasis of the video frequencies in the transmitter and corresponding de-emphasis in the receiver reduces the noise bandwidth and results in about 6 dB more sensitivity or twice the distance for a P4 to 5 picture. However, you cannot mix those with and without the network or you will get very distorted video or unstable sync.

The 4 standard US ATV frequencies are shown in bold and are selected on the digiswitch by a single one and the 3 others at zero for ease of use.

De-emphasis detail: The photos and schematic show the network mounted in a Radio shack 270-235 aluminum box. Run a short RCA plug shielded jumper between the receiver video out jacks and the de-emphasis box. To make up for the loss through the network, turn up the video gain pot, see photo, for 1 Vp-p output into a 75 Ohm resistive termination. Parts can be obtained from Mouser Electronics: 47 uH - 43LS475, .0082 uF - 140-PF2A822J.

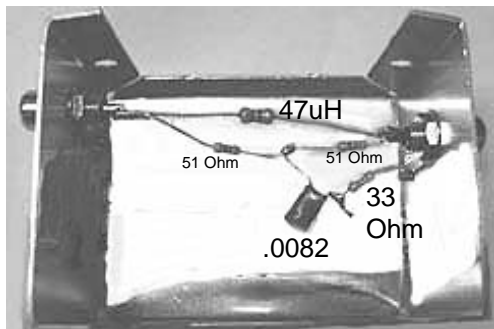
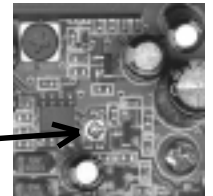

Twist one end of the 51 Ohm and .0082 uF leads together and then solder the parts as shown. Twist the other end of the cap with one end of the 33 Ohm resistor and solder together. Connect and solder the 47 uH to each RCA jack along with each end of the 51 Ohm resistors. Solder the 33 Ohm resistor lead to one of the ground lugs.

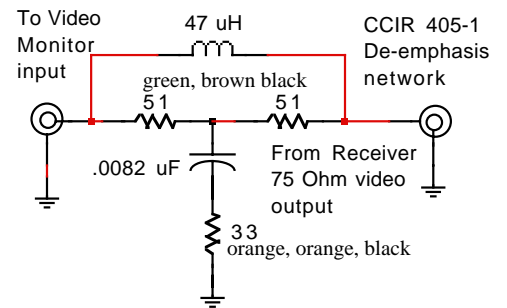

Audio squelch can be added this receiver using the circuit below and shown in the photo. Pin 7 on the downconverter can is the AGC test pin (counting left to right). The audio outputs will open with about a P4 picture. The transistor leads are used to make solder connections at the numbered locations on the resistor ends and transistor base as shown in the photo and schematic.

